

Lackebach Siegel, LLP *today!*

INTELLECTUAL PROPERTY ATTORNEYS SINCE 1923

In This Newsletter

- Page 1:**
Knock it Off!!! by Renée L. Duff
Attorney Profile: Howard N. Aronson
- Page 2:**
A Dream Come True For Fantasy Baseball Players
by Andrew F. Young
- Page 3:**
Patent Support Team
Knock it Off!!!, continued
- Page 4:**
I Lost My Trademark!!
by Howard N. Aronson
- Page 5:**
These Shoes Cost a Lot!
by Andrew F. Young
- Pages 6, 7, 8 & 9:**
Patents and Trademarks
- Page 10:**
Attorney Profile continued
- Page 11:**
Inventions of the Year
Acknowledgement Zone
A Dream Come True continued
- Page 12:**
RD's Observations & Notable Developments by R. Tofano

PATENT CORNER

Featuring patents recently issued to Lackebach Siegel clients

United States Patent Number:

7,396,261

CONTACT MAKER FOR POWER SEMICONDUCTOR MODULES AND DISC CELLS

The present invention relates to a contact maker for the gate terminal of power semiconductor components in disc cells and power semiconductor modules. Disposed above the power semiconductor component is a shaped member that incorporates in the region of the gate terminal a recess, and this recess, in turn, also incorporates a counter-support. The contact maker consists of a contact spring incorporating a pin-like extension at the end of the spring that contacts the gate terminal, and incorporating a connection created via a shaped metal element to a connecting cable for the external connection at the other end of the spring, and of an insulating sleeve with a contact spring disposed therein.

Continued on page 6

Knock it Off!!!

By Renée L. Duff

The closely watched Tiffany v. eBay lawsuit raised a number of major questions for Internet commerce. At issue was the question of just how much responsibility eBay need take for policing auctions of counterfeit Tiffany goods. Although an appeal is now pending, the decision is instructive for brand owners and online sellers alike. Claiming that eBay facilitated and allowed counterfeit items to be sold on its website, Tiffany sought to hold eBay liable for direct and contributory trademark infringement, unfair competition, false advertising, and a variety of related claims. Judge Richard J. Sullivan, however, didn't buy Tiffany's arguments, ruling that Tiffany failed to carry its burden with respect to all of its claims against eBay.

In its direct infringement claim, Tiffany complained that eBay had, for a time, "actively advertised the availability of Tiffany merchandise" both on eBay's own website and using sponsored links on search engines such as Google and Yahoo!. The Court, however, concluded that there was no reasonable way to describe the Tiffany merchandise without actually using the word "Tiffany." The alternative to using

the Tiffany mark, the Court explained, would be to require eBay to resort to "absurd circumlocutions" to describe the goods without using the mark, such as "silver jewelry from a prestigious New York company where Audrey Hepburn once liked to breakfast." In legal terms, the use of another's trademark to name or describe the good of the trademark owner is called "nominative fair use." The take-away for online sellers and brand owners alike is that as long as consumers are not confused as to the source of the goods, and that there is no implied endorsement of the activity by the brand owner, a seller is free to use a trademark of another to accurately describe goods being offered for sale.

Regarding contributory infringement, while neither side disputed that there is an amount of fraud that occurs on eBay, the parties disagreed on whose responsibility it is to police the eBay site. In particular, Tiffany contended that having been put on notice of the counterfeit problem, eBay was obligated to investigate and control the illegal activities of the individual sellers using its service. Judge Sullivan rejected Tiffany's contributory infringement claim stating:

Continued on Page 3

Attorney Profile

Position at Firm: Managing Partner

Howard N. Aronson

A Thirty Year Retrospective



As Managing Partner of the firm for almost two decades, Mr. Aronson has witnessed many changes in the practice of Intellectual Property (IP) law generally and significant transformations within the firm. Mr. Aronson started with Lackebach Siegel, who's roots as an IP boutique date back to the 1920's, over 30 years ago, as a patent attorney in the firm's Westchester office. At the time, the firm maintained three offices: New York City, Westchester (NY) and Arlington, Virginia (directly accessible to the United States Patent and Trademark Office), and was a full service IP firm having patent, trademark, search, licensing and litigation departments.

Continued on Page 10: Attorney Profile

Lackenbach Siegel *today* and Since 1923

A Dream Come True For Fantasy Baseball Players By Andrew F. Young

Fantasy baseball fans can breathe a sigh of relief following a recent ruling by the United States Court of Appeals for the Eight Circuit, in which it held that the use of Major League Baseball players' names and statistics in connection with fantasy baseball games does not violate the players' "right of publicity." Fantasy baseball, a game in which the participants draft and manage "fantasy" baseball teams comprised of real major league players, and the fantasy teams compete based on the real-life statistics of the players, has become hugely popular. As a result, scores of businesses have developed to serve the needs of fantasy owners, by providing statistics, suggestions, and forums for managing individual teams and leagues. Not surprisingly, Major League Baseball itself has attempted to profit from fantasy baseball's popularity.

C.B.C. Distribution and Marketing, Inc. ("CBC") provides fantasy baseball (and other sports) services over the Internet. In 1995, CBC entered into a license agreement with the Major League Baseball Players Association (the "Players Association"), under which the Players Association granted CBC the right to use the names of and information about major league players. CBC provides lists of Major League baseball players for selection by participants in its games.

In addition to fantasy sports games, CBC's website provides up-to-date information on each player to assist game participants in selecting players for, and trading players on their fantasy teams. This information includes

information that is typically found in box scores in newspapers, such as players' batting averages, at bats, home runs, etc.

Major League Baseball Advanced Media, L.P. ("Advanced Media") was formed in 2000 by the owners of Major League Baseball teams to serve as the interactive media and internet arm of Major League Baseball. In 2005, the Players Association granted the exclusive license for



the use of players' names and performance information "for exploitation via all interactive media" (including the Internet) to Advanced Media, leaving CBC without a license when its agreement with the Players Association expired at the end of 2004. The Players Association and Advanced Media operated under the presumption that the exclusive license gave Advanced Media the exclusive right to use players' names and statistics in connection with Internet-based fantasy baseball games.

During January 2005, Advanced Media sent a request for proposals (the "RFP") to various fantasy game operators and providers including CBC. The RFP invited CBC to submit a proposal under which it would enter into a license agreement with Advanced Media and participate in Advanced Media's fantasy baseball licensing program for the 2005 season. On February 4, 2005, Advanced Media offered CBC a license to promote Advanced Media's own fantasy baseball games on CBC's website for a royalty. More specifically, Advanced Media offered "a full suite of MLB fantasy games" and use of its

Patent Stats Bring Some Surprises

In 2007, there were 456,154 utility patent applications filed in the US Patent Office - 47.1% foreign originating - a decrease of foreign presence of almost 1% from 2006. Total design patent applications increased significantly over filings during 2006, to a total of 27,752, which represents an 8.76% increase in filing activity. Interestingly, there were 16,488 less utility patents granted in 2007 from the prior year, and 4,933 less patents granted to foreign residents. While foreign originating patent applications fell in 2007, foreign residents were granted 1.1% more utility patents in 2007 over the previous year.

Patents granted to independent inventors, unassigned to a company at the time of grant, fell significantly in 2007 to 18,506, a 10% decline from the previous year. California led as the residence of the most independent inventors having fourfold more patents than second place Florida. New York followed in third place with Texas not far behind.

Filing activity within the US Patent Office by country found Japan number one filing 37% of all foreign originating applications. Germany was second, filing 11% of all foreign applications with South Korea a close third, filing 10.7%. In 2007 there was a reverse, finally, of the prior downward trend of US originated patent applications as a percentage of total foreign originating applications.

Foreign countries, in order of rank for 2007 in total patent applications are: **Japan, Germany, South Korea, Taiwan, Canada, United Kingdom, France, Israel, Netherlands, and China.** But consider that Japan filed 78,794 applications in 2007 while China filed only 3,903.

There was a total of 182,930 patents granted in the U.S. in 2007, down from 196,437 in 2006. Japan accounted for 35,942 patent grants in 2007, 40% of all foreign originating patents. Germany had 10,012 patents granted during 2007 and the United Kingdom a distant 4,031.

WIPO finally presented statistics through 2006. The total number of applications filed across the world in 2006 is estimated to be 1.76 million, a 5% increase from the previous year. Between 2005 and 2006, China increased its global filings by 32%. The US Patent Office was the largest recipient of patent filings globally for the first time since 1963! Applications from Japan, the United States, South Korea, Germany and China accounted for 76% of the total patent filings globally in 2006. Chinese residents increased their share of total patent filings from 2% to 7% between 2000 and 2006, due to an increase in domestic filings.

There were 727,000 patents granted across the world in 2006, with Japan, US, South Korea and Germany receiving 73% thereof. Approximately 6.1 million patents were in force in 2006. The largest number of such patents were in the United States, approximately 2.1 million. But, surprisingly, the majority of such patents in force were owned by applicants from Japan.

Continued on Page 11

Patents, Trademarks, Copyrights

Knock it Off!!! continued from cover..

the law does not impose liability for contributory infringement on eBay for its refusal to take . . . preemptive steps in light of eBay's 'reasonable anticipation' or generalized knowledge that counterfeit goods might be sold on its website. Quite simply, the law demands more specific knowledge as to which items are infringing and which seller is listing those items before requiring eBay to take action."

Judge Sullivan was markedly impressed with eBay's "best practices" and the proactive steps taken by eBay to prevent counterfeit sales on its site. In fact, he was critical of Tiffany's choice of addressing the counterfeit goods found on eBay by suing eBay, instead of the individual sellers, noting that "aggressive pursuit of direct infringement actions against sellers might have had significant deterrent effect." The message to trademark owners is that if an online marketplace is complying with requests to remove items based on claimed infringement, then the marketplace is doing its job. The courts expect and demand the trademark owner play an active and leading role in the process. Many commentators have described this case as broadly affirming that policing counterfeits and other trademark misuse is squarely the responsibility of the trademark owner, not the responsibility of the online marketplaces.

In light of this ruling, what is a trademark owner to do? We have had the occasion to work extensively with eBay regarding counterfeit goods auctions, and while it is not a perfect system, the assistance eBay provides to trademark owners in combating illegal sales, the swiftness with which eBay responds to notices of infringement, and the commitment to making eBay a safe marketplace are quite impressive. This being the case, one should take advantage of what is offered to assist in protecting and policing one's brand. The other option is to litigate. It seems, however, eminently more practical to sue those who are actually doing the counterfeiting, than the marketplace itself. If you do feel compelled to sue eBay directly, experience has shown that the chance of success, at least in the United States, is slim.

By contrast, in a recent case against eBay the French courts awarded Louis Vuitton approximately \$63 Million based on the sale of counterfeit Vuitton goods on the French eBay site. eBay is appealing this decision. In contrast to the ruling in the U.S., the French court placed a heavier burden on eBay to detect and prevent the sale of counterfeit goods. Viva la difference!

In conclusion, it is wise and always highly recommended for trademark owners to be proactive and vigilant in the protection of their marks and the goodwill associated with them. While it certainly would be nice to think that a court could effectively mandate that someone else bear a portion of the cost and burden of policing one's marks in cyberspace or otherwise, regardless of the outcome of the French appeal, it should always be the trademark holder's burden, and is in their best interest, to police its own marks. Any help that may come from a marketplace, eBay or otherwise, is a bonus.

*To learn more about "The Online Marketplace" please contact:
Renée Duff at RDuff@Lackebach.com*

Patent Support Team

U.S. and Foreign Patent Departments



Pictured above (left to right) are: Rosemarie Speruzzi, Communications; Albert Feliciano, Litigation; Cathy Kynard, Docketing and Prosecution; Clotilda Koncz, Prosecution; Judy Hart, Prosecution; and Marina Krioutchkova, Prosecution.

For an 85 year-old Intellectual Property law firm, a dedicated and highly skilled support team is essential to assist the attorneys in preparing and filing patent applications worldwide. The firm prepares, files, prosecutes, and oversees a vast number of patent applications of all types, both domestically and internationally. Without the dedication and experience of its paralegals and support staff, the firm could not maintain such a strong partnership with the diversity of industries that it serves.

The secret of our success is the extensive level of training of our support personnel. Our team has both B.A. degrees and paralegal certifications. Our patent staff is continually training to keep their skill sets up to date, in order to meet the constantly changing patent prosecution requirements, and understanding electronic filing and access criteria.

In addition to patent drafting, filing and prosecution, the patent staff is responsible for extensive diligence, research and prior art consideration. Our team often crafts biotech and sequence listings; prepares chemical structure arrangements; manipulates research data; operates CAD or design imagery to support opinion, litigation, and prosecution efforts; and communicates with inventors and research facilities around the world to provide invaluable benefits to our partners in industry.

Our patent paralegals support all aspects of patent litigation from initial discovery, due diligence and invalidity searching, to design-around research and related opinion support. It is indeed the skill, experience, and dedication of our highly competent patent support staff that has allowed our patent program to gain praise and recognition.

I Lost My Trademark!!

By Howard N. Aronson

The sign read:

FOR SALE
nylon yo-yo's and
trampolines

Yo-yo's, aspirin, escalators, nylon, trampolines and cornflakes are all great products. But at one time, each word was a valuable trademark giving its owner the exclusive right to use such word to sell its own items. Bad business practices and inattentive lawyering likely caused the loss of those important rights. Today, each of these former trademarks has become the generic name for a product, available for use by all.

Imagine being the only company today legally able to sell a **Yo-Yo** brand string toy, or **TRAMPOLINE** brand jumping platform! All that is needed is a basic understanding of trademark law and good trademark counsel.

A trademark is any word, name, symbol, or device, or any combination thereof, used by a manufacturer to identify its goods and distinguish them from those manufactured or sold by others. A trademark is not the name of the product itself. When used correctly, the generic name of the item follows the trademark: **BARBIE®** dolls; **ROLLERBLADE®** in-line skates. If used and protected correctly, there might still be: **ASPRIN** brand pain reliever and **ESCALATOR** brand moving stairs.

A trademark is a proper adjective, best capitalized, italicized, bolded or otherwise distinguished from the rest of a sentence, and followed by the generic name of the product it identifies. Proper trademark usage includes:

- Juxtaposing the trademark with the generic, descriptive or common name

of the product;

- Never using a trademark as a noun or the name of the product;
- Highlighting or setting off the trademark from the adjoining text or the descriptive name of the product;
- Marking the trademark ("tm" or ® if registered) so the public is advised that it is not a product description; and
- Maintaining uniformity of presentation - never pluralizing or otherwise modifying its grammatical status as an adjective.

What words can be safely used as a Trademark?

➤ Only designations that will not infringe the rights of a third party. So a trademark search should be conducted.

➤ And only words that are not too descriptive of the item. ICE CREAM is unavailable as a trademark for a frozen confectionary – but a wonderful trademark for children's clothing or toys.

Not all trademarks are created equally. Thus, the courts have created the "distinctiveness continuum" to determine the strength of a trademark for purposes of enforcement. From strongest to weakest the categories are:

fanciful; arbitrary; suggestive; descriptive; and generic marks.

If the proposed word is descriptive of the product, it is not a protectable mark unless it acquires a special association with the product over years of use.

Trademark ownership is derived from the actual use of the trademark at point of purchase. Use alone, even without registration, can result in ownership of trademark rights! There are benefits, however, to obtaining a trademark registration. It creates constructive notice of your rights, meaning that an infringer cannot avoid liability simply by claiming not to have had actual knowledge of your trademark. Registration also serves



as evidence of the validity of the mark, ownership of the mark, and the exclusive right to use the mark in commerce. Best of all, it confers the right to prevent the use of any confusingly similar mark on the same or "related" goods or services. And, as many products sold in the U.S. are manufactured overseas, a federal registration allows the owner to record its mark with the U.S. Customs Service to help avoid infringements.

Why did YO-YO and TRAMPOLINE lose their rights?

A trademark owner is obligated to police the use of its trademark to insure that others are not infringing or misusing the trademark, and most importantly, not to misuse the mark itself as a descriptive reference to the goods. Proper usage would have been to promote and sell "**TRAMPOLINE** jumping platforms" - not "a trampoline." And proper practices would have been to educate the public as to the correct usage of the mark and to take affirmative actions to address misuse or infringement.

Had better business practices and lawyering been followed years ago, only one company could now be selling **THERMOS** insulated containers, or distributing **CORNFLAKES** cereal. Poor practices could have sent **TEFLON** brand coatings that are used on pots and pans into the ranks of nylon and lanolin. Failure to follow good business practices and consult qualified trademark counsel often results in the loss of valuable trademark rights and business advantage.

To learn more about Protecting Trademarks please contact:
Howard N. Aronson, HAronson@Lackebach.com

These Shoes Cost a Lot!



By Andrew F. Young

DSW, a shoe retailer, notified Shoe Pavilion that it was infringing one of DSW's patents for a shoe display rack. Shoe Pavilion quickly agreed to modify its displays and, over a period of seven months, replaced all of them with modified non-infringing displays. Nonetheless, DSW sued Shoe Pavilion for the infringement.

With respect to damages for seven months of infringement by Shoe Pavilion, the trial court found that DSW was not entitled to any money as a matter of law, because, immediately upon receipt of DSW's notice of infringement, Shoe Pavilion took reasonable steps and timely removed all of the infringing shoe displays.

Unfortunately for Shoe Pavilion, the trial court misapplied the law. The legal issue for was whether Shoe Pavilion was liable for damages for infringement occurring after receipt of actual notice. The Supreme Court had previously explained that a patentee may indeed recover damages for infringement that continues after actual notice

is provided. Accordingly, the appellate court in the DSW case correctly held that

“without a doubt, the law offers an infringer no exception to liability for the time it takes to terminate infringing activities, no matter how expeditious and reasonable its efforts.”

Good faith efforts to change are not enough, however speedy. Damages are owed for the time of infringement while Shoe Pavilion phased out use of the displays in its stores. Interestingly, had DSW marked its own displays with its patent number that would have provided, as a matter of law, “constructive notice” to Shoe Pavilion and damages would have accrued from the first use of the infringing racks by Shoe Pavilion even prior to receiving DSW's letter. Infringing “Constructive notice” by way of patent number marking of products is effective even if an infringer does not actually see or know of the marked product or the existence of the patent. Patent owners are, accordingly, strenuously advised to mark all their patented items with patent numbers.

To learn more about Patents please contact: Andrew F. Young, AYoung@Lackebach.com

The Courts Toy With Copyrights



Some manufacturers bless copyright protection in the U.S. for successfully protecting their toy products. But such protection does not cover a toy that has “an intrinsic utilitarian function that is not merely to portray the appearance of the article,” unless “such design incorporates features that can be identified separately from the utilitarian aspects of the article.”

A California court recently proclaimed that a toy that could actually fly, a small helicopter, was entirely protectable by copyright because the appearance of a flying product is not intrinsically functional when the product seeks to portray a real helicopter. But if a “toy” actually flies, many would argue convincingly that parts of the construction must be functional, and therefore incapable of copyright protection. A bright line distinction was made by the California court between “toys” that emulate the appearance of real airplanes—or other objects—and a flying object “toy” that bears no resemblance to actual helicopters, airplanes, or missiles.

Why are only some toys entitled to copyright protection?

Copyright protection extends to pictorial, graphic, or sculptural works. A useful article is considered protectable only if the design incorporates features that can be identified separately from the utilitarian aspects of the article. In plain words, works of artistic craftsmanship are protected for their form but not for their mechanical or utilitarian function. The Copyright Act defines useful articles as excluding works created merely to portray the appearance of the article.

So behold the power of copyright protection for “toys,” defined as, “something... that is paltry or trifling... a trinket or bauble... something for a child to play with.” We are told by one court that the mechanical parts of a flying saucer, the motor and main propeller, are not entitled to copyright protection; but the balance can be protected by copyright even though not emulating a “real” helicopter, plane, or missile. Meanwhile, another court declares that flying toys that bear no resemblance to actual helicopters or airplanes may have an intrinsic utilitarian function and accordingly not be subject to copyright protection. The courts also tell us that

miniature motorcycles that may be ridden serve a utilitarian function because they can transport a person, hence, a useful article and denied copyright protection for its appearance. But what if one makes the same motorcycle far smaller, a “toy” that merely moves itself without being able to transport a child, and made to portray the appearance of an actual “real” motorcycle? Certain toy airplane cases teach that such non-rideable motorcycle would qualify for copyright protection.

Court cases considering other types of toys have eased the process of understanding what is capable of copyright protection:

Wind-Up Dolls—While the look of a wind-up doll can be the subject of copyright protection, the idea of a walking or crawling doll and the locomotion mechanism are not protectable.

Model Airplane—A toy airplane that does not fly is merely a model that portrays a real airplane, and as such entitled to copyright protection.

3-D Puzzles—Where design elements can be identified independently of functional considerations, a three-dimensional puzzle is entitled to protection.

Nose Masks—Nose masks are not useful articles and are protectable as sculptural works.

Puppets—Protection extends to the artistic aspects of puppets, but not the mechanical features.

Why does my attorney hedge?!

It is impossible to provide an easy and dependable legal answer as to the extent of copyright protection for all toys. What is clear, however, is that toy manufacturers should promptly seek to register their toy designs with the Copyright Office. And provide a copyright notice on the toy and packaging, as such helps enforcement efforts and alerts the competition that you consider the product to be protected. But the lack of a copyright notice does not make it safe to copy a toy.

This article was also published in *The Toy Book*, September, 2008

To read the full text of an article or Listings in this newsletter please go to our website at: www.Lackebach.com - Page 5

Patents, Trademarks, Copyrights

PATENT CORNER

Continued from Page 1

CONTACT MAKER FOR POWER SEMICONDUCTOR MODULES AND DISC CELLS

United States Patent Number:

7,396,261

Date of Patent
July 8, 2008

Assignee:

Assigned to Semikron Elektronik GmbH & Co., KG, Nuremberg (Ger.)

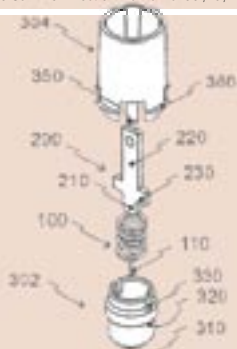

Notable, recent LS Patents

METHOD FOR SIMPLIFYING THE EXCHANGE OF A SIM CARD OF SUBSCRIBERS OF DIGITAL MOBILE COMMUNICATIONS NETWORK

Patent No.: 7,280,845

Assignee: T-Mobile Deutschland GmbH, (Germany)

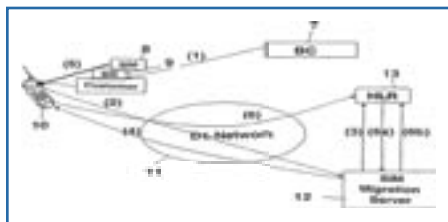

HAND TOOL HANDLE

Patent No.: D553,907

Assignee: Dexter-Russell, Inc. (US)

TELESCOPING LANDING GEAR

Patent No.: 7,377,488

Assignee: SAF-Holland, Inc. (US)

TBI-MIX CAULKING GUN

Patent No.: D568,125

Assignee: P C Cox Limited (Great Britain)

ANTI-JAMMING DEVICE FOR PRINTERS PUT IN PUBLIC PLACES

Patent No.: 7,322,760

Inventor: Custom Engineering Spa, (Italy)

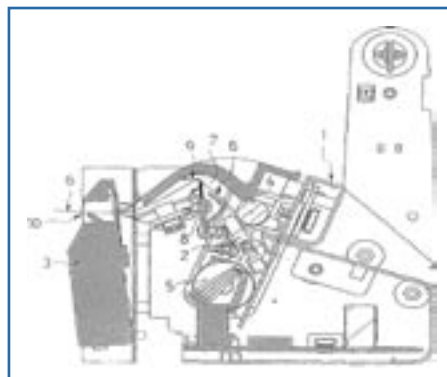

CIRCUIT CONFIGURATION WITH ERROR DETECTION FOR THE ACTUATION OF POWER SEMICONDUCTOR SWITCHES AND ASSOCIATED METHOD

Patent No.: 7,417,880

Assignee: Semikron Elektronik GmbH & Co. (Germany)

VIDEO PROJECTOR FOR DOME SCREEN

Patent No.: 7,293,881

Inventor: Kabushikigaisya Goto Kogaku Kenkyujo (Jp)

INFORMATION SEARCHING METHOD, INFORMATION SEARCHING PROGRAM, AND COMPUTER-READABLE RECORDING MEDIUM ON WHICH INFORMATION SEARCHING PROGRAM IS RECORDED

Patent No.: 7,346,614

Assignee: Advanced Industrial Science and Tech., (Jp)

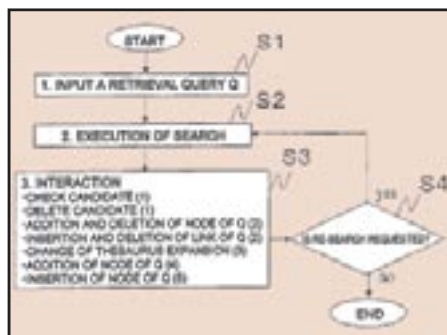

METHOD FOR PRODUCING AN ELECTROCHROMIC DEVICE AND SAID ELECTROCHROMIC DEVICE

Patent No.: 7,295,361

Assignee: Close Joint Stock Company "Technoglass Engineering" (Russia)

LIGHTING FIXTURE

Patent No.: D565,228

Assignee: Yamagiwa Corporation (Japan)

PROXY FOR CALLS TO ROAMING SUBSCRIBER AND PROXY METHOD FOR CALLS TO ROAMING SUBSCRIBER

Patent No.: 7,277,698

Assignee: Huawei Technologies Co., Ltd. (China)

FRESIA CUT JEWEL

Patent No.: D569,296

Assignee: Gitanjali Gems Limited (India)

PRY BAR HANDLE

Patent No.: 7,293,331

Assignee: Mayhew Steel Products, Inc. (US)

SURGICAL SCRUB BRUSH AND CLEANER APPARATUS

Patent No.: 7,260,863

Assignee: Biomed Packaging System Inc., (US)

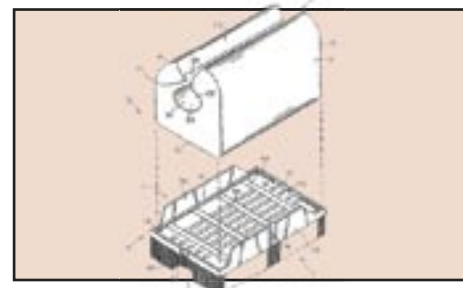

ARRANGEMENT AND METHOD FOR PRODUCING THERAPEUTIC INSOLES

Patent No.: 7,310,564

Assignee: Vabene GmbH & Co. KG (Germany)

TRANSMISSION SYSTEM FOR TRANSMITTING DATA VIA CURRENT CONDUCTING BRANCHES

Patent No.: 7,327,222

Assignee: Nokia Corporation (Finland)

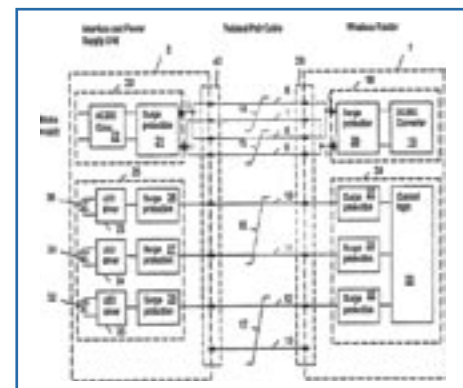

AGENT AND COMPOSITIONS COMPRISING THE SAME FOR INHIBITING LIPASES AND PHOSPHOLIPASES IN BODY FLUIDS, CELLS AND TISSUES

Patent No.: 7,368,529

Assignee: Reliance Life Science Pvt. Ltd., (India)

Domains, Internet and Advertising Law

TRADEMARK CORNER

Notable, recent LS Trademarks

BANJEES

Registrant: Thompson-Weiler Enterprises LLC (USA)

THE TAKEAWAY

Registrant: WNYC Radio (USA)

VOLONA

Registrant: Beijing Edifier Technology Co., Ltd. (China)

GATEWAY GROUP ONE

Registrant: Gateway Security Inc. (USA)



KINPU

Registrant: Kabushiki Kaisha Mitsukan Group (Japan)

PL

Registrant: Park Lane Hotel, Inc. (USA)

ARNOLDI

Registrant: Arnoldi, Gianfranco (Mexico)

JAPI

Registrant: Japi S/A. Indústria e Comercio (Brazil)

AVANTAIR

Registrant: Avantair, Inc. (USA)

IQUOTESURFER

Registrant: Cost Containment Group, Inc. (USA)

LOCO MATICO

Registrant: La Fortuna S.A. (Chile)



DEXTER THE EDGE SINCE 1818

Registrant: Dexter-Russell, Inc. (USA)



SIMPLE SOLUTIONS

Registrant: W. Atlee Burpee Company (USA)

COMPREHENSIVE

Registrant: VCOM International Multimedia Corporation (USA)

SOA FASTRACK

Registrant: Scort (France)

VOYAGES TELEVISION LUXURY TRAVEL NETWORK

Registrant: Television Voyages, Ltd. (Hong Kong)

PATTERN FINDER

Registrant: Orchard Yarn and Thread Company, Inc. dba Lion Brand Yarn Company (USA)

MAYUHANA

Registrant: Yamagiwa Corporation (Japan)

FLEXATION

Registrant: Aerogroup International Holdings, Inc. (USA)

Lace Ball Logo

Registrant: Sferra Bros. Ltd. (USA)



MEDIASEED

Registrant: Medialink Worldwide Incorporated (USA)

NINA GIRLS

Registrant: Nina Footwear Corp. (USA)



CSK

Registrant: CSK Holdings Corporation (Japan)

ZEN

Registrant: Shiseido Co., Ltd. (Japan)



H HYUNDAI PRIORITY MY CUSTOMER – MY PRIORITY.

Registrant: Hyundai Motor America (USA)



P PATRIOT HEALTH

Registrant: Patriot Health, Inc. (USA)

AQREX

Registrant: Aqrex Limited (United Kingdom)

OPTICAL REFLECT MOUSE

Registrant: Fujitsu Component Limited (Japan)

POLIAKOV

Registrant: Société des Vins et Spiritueux; LA MARTINQUAISE (France)

T. HARV EKER

Registrant: True Power International, Ltd. (USA)

VECCHIA MALGA

Registrant: Famiglia Chiari S.r.L. (Italy)



MAGLIO

Registrant: Maglio Arte Dolciaria S.r.L. (Italy)

REAL TIME DELIVERY.

Registrant: Velocity Express, Inc. (USA)

TOUGHARTIST

Registrant: Matsushita Electric Industrial Co., Ltd. (Japan)

INFOTRACS

Registrant: International Technology Solutions, Inc. (USA)

Continued on Page 9

More Patents

PATENT CORNER

Continued from Page 6: Patent Corner

SPRING CLAMP HINGE

Patent No.: D560,993
Inventor: Olympia Group, Inc. (US)

SWAY BAR BUSHING AND SYSTEM

Patent No.: 7,341,245
Assignee: Research & Mfg. Corp. of America (US)

FISH TAPE PLIERS

Patent No.: 7,415,913
Assignee: Channellock, Inc. (US)

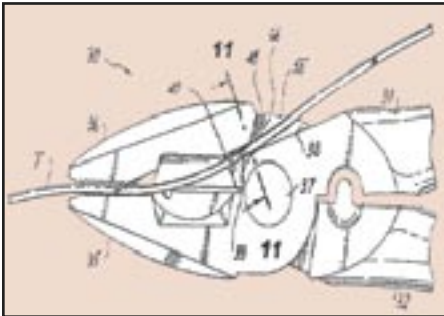

SIMPLIFIED AND STABLE HAT CONSTRUCTION WITH ROTATABLE BRIM

Patent No.: 7,240,373
Inventors: 3Sixty Innovations, LLC (US)

HINGE FOR PACKAGING HOUSING

Patent No.: D562,108
Assignee: Emil Pester GmbH (Germany)

PENDANT

Patent No.: D547,481
Assignee: L & C Lighting Technology Corp. (Taiwan)

MASS SPECTROMETER METHOD AND APPARATUS FOR ANALYZING A SAMPLE IN A SOLUTION

Patent No.: 7,247,495
Inventor: Aviv Amirav (Israel)

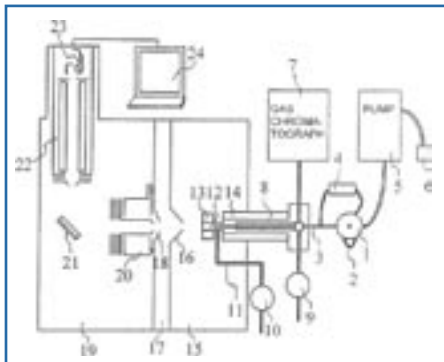

PLUG-IN COUPLING FOR FLUIDIC SYSTEMS

Patent No.: 7,338,094
Assignee: VOSS Automotive GmbH (Germany)

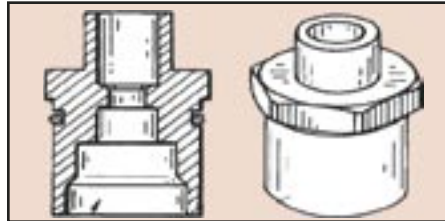

TRANSPORTATION DEVICE HAVING A BASKET WITH A MOVABLE FLOOR

Patent No.: 7,306,244
Assignee: Kaback Enterprises, Inc. (US)

ELECTRIC SWITCH, ESPECIALLY A PIEZO SWITCH WITH OPTICAL AND/OR MECHANICAL FEEDBACK OF THE SWITCHING OPERATION

Patent No.: 7,250,708
Assignee: DYNA Systems GmbH (Germany)

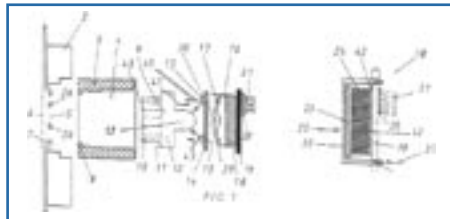

LUGGAGE TAG

Patent No.: D567,294
Assignee: A & A Merchandising Inc. (US)

HORN DESIGN

Patent No.: D568,195
Assignee: Wolo Mfg. Corp. (US)

AUTOMATIC SIGNALING DEVICE FOR AUTOMOBILES

Patent No.: 7,342,487
Assignee: Jose Maria Del Estal Villar (Spain)

HAIR STYLING APPARATUS

Patent No.: D567,439
Assignee: Each2Each, Inc. (US)

INSULATION DISPLACEMENT CONNECTOR ASSEMBLY AND SYSTEM ADAPTED FOR SURFACE MOUNTING ON PRINTED CIRCUIT BOARD AND METHOD OF USING SAME

Patent No.: 7,320,616
Assignee: Zierick Manufacturing Corp. (US)

THERMAL BODY

Patent No.: D555,090
Assignee: Durable Systems, Inc. (US)

PIVOT POT HINGE

Patent No.: D566,518
Assignee: Allstar Marketing Group, LLC (US)

UTILITY KNIFE HANDLE

Patent No.: D560,998
Assignee: THyde Tools, Inc. (US)

SHOE SOLE

Patent No.: D575,039
Assignee: Aerogroup International Holdings, Inc. (US)

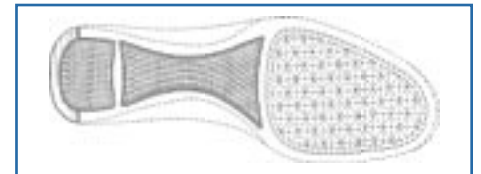

METHOD AND SYSTEM FOR THE AUTOMATIC COLLECTION AND CONDITIONING OF CLOSED CAPTION TEXT ORIGINATING FROM MULTIPLE GEOGRAPHIC LOCATIONS, AND RESULTING DATABASES PRODUCED THEREBY

Patent No.: 7,268,823
Assignee: Medialink Worldwide Incorporated (US)

METHOD FOR IMPROVING SECURITY AND ENHANCING INFORMATION STORAGE CAPABILITY, THE SYSTEM AND APPARATUS FOR PRODUCING THE METHOD, AND PRODUCTS PRODUCED BY THE SYSTEM AND APPARATUS USING THE METHOD

Patent No.: 7,261,235
Assignee: Secure Symbology, Inc. (US)

POWER SEMICONDUCTOR MODULE WITH AUXILIARY CONNECTION

Patent No.: 7,288,842
Assignee: Semikron Elektronik GmbH & Co (Germany)

JEAN POCKETS

Patent No.: D558,954
Assignee: Indigo Group U.S.A., Inc. (US)



TOTE FOR BOTTLES

Patent No.: D564,215
Assignee: Built NY, Inc. (US)

HEADLIGHT

Patent No.: D562,475
Assignee: Primus AB (Sweden)

More Trademarks

TRADEMARK CORNER

Continued from Page 7: Trademark Corner

GRUPPO BANCA LEONARDO

Registrant: Gruppo Banca Leonardo S.p.A. (Italy)

ANNAITE

Registrant: Xingyuan Tyre Group Co., Ltd. (China)

MONTI GIORGIO MONTI

Registrant: Monsieur Abderazak Ben M'Henni (France – Individual)



KNICKERS BY CINEMA ETOILE

Registrant: Frederick's of Hollywood Group Inc. (USA)

CHANEX

Registrant: Oxford Biomedica PLC (United Kingdom)

ELANTRA TOURING

Registrant: Hyundai Motor America (USA)

CC SQUARED BY COLIN COWIE

Registrant: Colin Cowie Lifestyle (USA)



ZNYC

Registrant: ZNYC Music, Inc. (USA)

LTE LIFT TRUCK EQUIPMENT

Registrant: L.T.E. Lift Truck Equipment S.p.A. (Italy)

PROSAVIN

Registrant: Oxford Biomedica PLC (United Kingdom)

RCL

Registrant: Toko Kabushiki Kaisha Ta Toko, Inc. (Japan)

ASW

Registrant: aSmallWorld Holdings, Inc. (USA)

D'GARI

Registrant: Productos Alimenticios y Dieteticos Relampago, S.A. de C.V. (Mexico)

SCNB SUFFOLK COUNTY NATIONAL BANK

Registrant: Suffolk County National Bank (USA)

IMPULSIVE

Registrant: Impulse Enterprises, Ltd. (Cayman Islands)

FAITH CONNEXION

Registrant: Faith Connexion (France)



STARKLE MATE

Registrant: Mitsui Chemicals, Inc. (Japan)

TRANSAIR

Registrant: Yamagiwa Corporation (Japan)

MARRAKECH

Registrant: Branic International Realty Corp. (USA)



HIBUN

Registrant: Hitachi Software Engineering Co., Ltd. (Japan)

PRONUTRO

Registrant: Pioneer Foods (Proprietary) Limited (South Africa)

SINDOPOWER

Registrant: Semikron International GmbH (Germany)

JOUER LE STYLE

Registrant: Jouer Le Style di Massimo e Paolo Pollini S.r.L. (San Marino)

BACHILLERATO INTERNACIONAL

Registrant: International Baccalaureate Organisation (Swissw)

YKK

Registrant: YKK Corporation (Japan)



EXCALIBUR

Registrant: Pentel Kabushiki Kaisha (Japan)



MISCELA MASINI

Registrant: Esse Caffè S.p.A. (Italy)

SOUND ASSOCIATES INCORPORATED

Registrant: Sound Associates, Inc. (USA)

HERCHCOVITCH; JEANS

Registrant: A H Confeccoes Ltda (Brazil)

DESIGN OF V-LO KNIFE HANDLE

Registrant: Dexter-Russell, Inc. (USA)



ONY-TEC

Registrant: Polichem S.A. (Luxembourg)

INGENASA

Registrant: Inmunologia y Genetica Aplicada, S.A. (Spain)

ROSEDEW

Registrant: Tianjin Foodstuffs Import & Export Co. Ltd. (China)

RUFFLES

Registrant: Orchard Yarn and Thread Company Inc. dba Lion Brand Yarn Company (USA)

REAL TIME VIRTUALIZATION

Registrant: Virtuallogix SA (France)

ANI-MOVIE

Registrant: Jazwares, Inc. (USA)

HYDE

Registrant: Hyde Tools, Inc. (USA)



The Lackenbach Business Model

Attorney Profile Continued from Page 1: Howard N. Aronson

With the expansion of designer trademarks and licensing in the 1970's, Mr. Aronson subsequently worked in the trademark department and was responsible for iconic designer licensing during its exponential growth during that time period. Mr. Aronson then moved into the litigation department as the infringements and piracy of designer brands became prevalent. He eventually headed the litigation department for many years until being named Managing Partner, in view of his broad experience in all facets of the firm's operations, and considering his exposure to different IP firms. Mr. Aronson started his career working for a very small IP boutique, Goldfarb & Chalson, and subsequently was an associate at Ladas & Parry, then one of the largest IP boutiques in the country.

Mr. Aronson was an important part of the metamorphosis of Lackenbach. As technology developments and rule changes obviated the need for direct access to the Patent and Trademark Office, the firm closed its Arlington, Virginia office. Further technology developments, together with the globalization of the firm's client base, led to the forward thinking centralization of operations in the Westchester office.

Most significantly, Mr. Aronson's orchestrated the unique evolution of Lackenbach through staffing policies which focused on hiring only with very experienced IP attorneys. Presently, there is no attorney at

Lackenbach Siegel with less than 15 years of IP experience - the average being over 20 years. Lackenbach, under Mr. Aronson's control for the last decade, has become renowned for its sub-specialization by attorney, permitting Lackenbach to staff matters with fewer attorneys and complete assignments in less time, resulting in lower fees than typically charged by large firm counterparts. The Westchester location, coupled with high efficiency (resulting from experience and sub-specialization), equate to a lower overhead for the firm and the resulting ability to pass along lower billing rates. The unique business model - offering only highly experienced attorneys at lower than average rates - has been a formula for the firm's success and longevity. In recent years, many other IP boutiques have disappeared through merger, acquisition, or failure, while Lackenbach has evolved and thrived. The Lackenbach business model, first introduced by Mr. Aronson 15 years ago, has been and remains unique, attractive to discriminating clients, and eminently successful.

Mr. Aronson presently prides himself in being a contract author to LexisNexis, the largest publisher in the IP field, in connection with four publications. And despite Lackenbach's relatively modest size in the current era of the "mega-firm," Mr. Aronson routinely ranks among the top ten trademark filers nationally.

EDUCATION

DREXEL UNIVERSITY, Philadelphia, PA
Bachelor of Science - Civil Engineering, with Distinction

NEW YORK LAW SCHOOL, New York, NY
Juris Doctor

BOOKS

- "Protecting Designs by Trademarks, Copyrights and Design Patents," *Intellectual Property Counseling and Litigation*, LexisNexis.
- "Trademark Management," *Business Law Monographs*, LexisNexis.
- "Corporate Counsel Solutions, Intellectual Property Management: Strategies & Tactics," LexisNexis
- "Acquiring and Protecting Intellectual Property Rights," *Business Law Monographs*, LexisNexis

PUBLICATIONS

- "Trade Dress After Two Pesos: The Circuits Are Still Split, But Which Has it Right?," *The National Law Journal*, 1997.
- "Global Colorblindness to Trademarks is Dying," *The National Law Journal*, June 5, 1995.
- "Protection Against Use or Pictures of One's Goods by a Competitor Wastes Away Under 'Waist Away'," *The Trademark Reporter*, Vol. 73, No. 1, January-February, 1983.

NOTABLE SEMINARS

- "Color Me Pink," *Hand Toots Institute*, 1986.
- "Patents, Trademarks & Copyrights: What You Need to Know," *American Hardware Manufacturers Association*, 1986.
- *Dimensions: A Forum for Trademark Paralegals*, *United States Trademark Association*, "United States Trademark Searching," 1988.
- *Launching a Product in the United States*, *United States Trademark Association*, "Trade Dress," 1990.
- "The Role of Intellectual Property in a Free Market Economy," *Moscow and Voronezh, Russia*, 1993.
- "Trademark Management," *Tokyo, Japan*, 1996.
- "United States Trademark Basics," *Tokyo, Japan*, 1996.
- "Dress For Success," *International Trademark Association Spring Forum*, "Personal Care and Industrial Products Protection," 1997.
- "Trade Dress - The Forgotten Trademark Right," *Vail, Colorado*.
- "Patent Developments and Overview," *Law Education Institute*, 1998.
- Chairman "Intellectual Property Management: Developing a Corporate Intellectual Property Strategy," *New York, New York*, April, 1998.
- Panelist - "Fundamentals of Intellectual Property," *Pace University Law School, CLE Program*, June, 1998.
- Panelist - "Intellectual Property Business and Financing Transactions: Capitalizing on Your Assets-Using Intellectual Property Assets as Collateral for Financing," *New York, New York*, November 1998.
- "Fundamentals of Intellectual Property," *Pace University Legal Education Seminar*, January 19, 1999.

More Patents & Trademarks News

Fantasy Baseball... "Right of Publicity"... Continued from Page 2

A Dream Come True For Fantasy Baseball Players

"online presence and customer relationships, in conjunction with [MLB's] marks, to promote the MLB.com fantasy games" in exchange for 10% of all related revenue. Advanced Media was not offering CBC a license to promote CBC's own fantasy games, but only Advanced Media's games.

On February 7, 2005, CBC filed a suit against Advanced Media seeking a declaration that CBC had the right to operate its own fantasy baseball games over the Internet, using Major League Baseball player's names and statistics. Advanced Media countered that it owned the exclusive rights to statistics associated with players' names and could preclude CBC, and anyone else from using this statistical information to provide fantasy baseball games to the consuming public.

The dispute boiled down to whether or not the players' names and statistics were protected from use by CBC by the players' rights of publicity. The right of publicity generally protects against the commercial use of a person's name, likeness, or other indicia of identity without the person's consent. The right of publicity is a relatively new right, first recognized in New York in 1953 in a case, coincidentally, involving the right to use pictures of baseball players on baseball cards (or as the reported decision quaintly put it, in connection with the sale of chewing gum). There is no federal right of publicity; rather the law regarding the right of publicity varies from state to state. Some states (about 30, including New York, California, Illinois, Massachusetts, Missouri, and Tennessee) recognize and protect the right, while many do not (including Alaska, Arkansas, and Mississippi). Some states recognize the right only for celebrities, while others recognize every person's right.

The Supreme Court has held, however, that the right of publicity must be balanced and limited by the First Amendment. For example, newspapers, magazines, and radio and television stations have the right to use a person's name and photo in reporting on the news. These First Amendment rights go well-beyond traditional news reporting, and generally protect the use of names, photos, and the like in connection

with anything that is considered newsworthy.

Under Missouri law, to make out a claim for the violation of the right of publicity, Advanced Media was required to prove "(1) that defendant used plaintiff's name as a symbol of his identity (2) without consent and (3) with the intent to obtain a commercial advantage."

Even though the Court did not find a violation of the Missouri law, it nonetheless went on the balance the right of publicity against CBC's First Amendment rights. The Court first listed the traditional justifications and benefits of the right of publicity, including economic incentives, the efficient allocation of resources, protection against consumer deception, and the prevention of unjust enrichment, then balanced these against CBC's right of free expression. Eventually, the Court held that CBC's First Amendment rights trumped any right of publicity which may exist.

Advanced Media and the Players Association appealed to the Eight Circuit Court of Appeals that, agreed with the District Court's First Amendment analysis, holding that "the information used in CBC's fantasy baseball games is all readily available in the public domain, and it would be strange law that a person would not have a first amendment right to use information that is available to everyone." The Court also used Major League baseball's own past actions and legal arguments against it, citing a California court, "*Major league baseball is followed by millions of people across this country on a daily basis ... The public has an enduring fascination in the records set by former players and in memorable moments from previous games ... The records and statistics remain of interest to the public because they provide context that allows fans to better appreciate (or depreciate) today's performances.*" The Court concluded that the "recitation and discussion of factual data concerning the athletic performance of [players on Major League Baseball's website] command a substantial public interest, and, therefore, is a form of expression due substantial constitutional protection."

To learn more about "Right of Publicity" please contact: Andrew F. Young at AYoung@Lackebach.com

INVENTIONS OF THE YEAR

Time Magazine named the iPhone as the best invention in its listings of the top innovations in 2008. Their basis was not the technological achievement, but instead the blending of known technology and design to make a product for a large consumer market.

The World Intellectual Property Organization (WIPO) awarded top inventor prizes to a young woman, Reem I. Khojah, for an anti-cancer agent from an odd source – camel's urine; to Ahmed Basfar for a holgen-free flame retardant compound used globally in wires and cables; and to Wan Tarmeze for engineered wood products made from waste biomass from oil palm plantations.

Thailand awarded an outstanding inventor medal to Woradech Kaimart for a "Fire Ball" able to extinguish a fire within a controllable radius when simply thrown at the blaze.

The climate change challenges fostered numerous top innovations in 2008. **MIT's Media Lab** created a self-stacking car and **Venturi Electric** created the first energy autonomous vehicle running, surprisingly, on solar and wind power.

Acknowledgement Zone

Lackebach Siegel's Howard N. Aronson Ranked 11th in Nation.

Howard N. Aronson was ranked 11th of all trademark attorneys nationwide by the **Trademark Insider, Annual Report 2007** based upon applications submitted to the USPTO.

Such accomplishment prompted **Corporation Service Company** to grant Aronson an **Attorney Award** recognizing his top standing in the nation.

Lackebach Siegel continued during 2007, a longstanding tradition of being positioned among the top filers in the nation.

Foreign Trademark Department

RO'S OBSERVATIONS

By Rosemarie B. Tofano

Macao – The New Shopper's Paradise –

This grouping of islands one hour away from Hong Kong is now a vacation and shopping destination. Trademark registration should be seriously considered for Macao, as registration in China or Hong Kong will not extend to this jurisdiction even though it is an independent region of the People's Republic of China. Registrations granted or applications filed in Portugal prior to 1988 may be extended to Macao. As Macao is a first to file jurisdiction, care must be taken to protect rights at an early date. During 2007, over 7,200 trademark applications were filed. Applications are filed in either Chinese or Portuguese languages, but the database of applications and registrations is searchable in English. Applications must be filed in paper form, not on-line, and take about one year to process.

Taiwan – Need for Chinese Version of Foreign Marks –

When local Taiwan companies, even if agents for a foreign company, file and achieve registration of the Chinese ver-

sion of a well-known foreign language mark, it may be difficult for the legitimate owner of such well-known mark to obtain ownership of the Chinese version if a dispute ensues. Such difficulty exists even when there is an agreement between the companies requiring assignment upon termination of a business relationship. The better procedure is to seek registration of one or more Chinese versions of your mark when involved with local agents or manufacturer. Care should be taken to learn of and protect connotative and phonetically similar Chinese designations to your mark if involved in commerce in Taiwan.

Thailand – Well Known-Marks Have Great Value –

Foreign applicants account for about one half of all marks recorded in Thailand as well-known marks. The criteria to be eligible as a well-known mark includes the use, advertising and customer recognition in Thailand. Well-known mark registration prevents registration of a confusingly similar mark in any class and provides irrefutable evidence of the fame of the mark. When used as a basis of a cancellation or opposition, a well-known mark recordation eliminates the need for proof of customer recognition and provides significant evidentiary benefits such as fame of the mark. Service Marks are eligible for well-known mark recordation as well

as Certification and Collective Marks.

Canada – New Disclaimer Practice –

The Canadian Trade-Marks Office historically required disclaimers where a mark contained a descriptive component. The Trade-Mark Office has now determined that it will "generally no longer require an applicant for registration of a trade-mark to enter disclaimers." When only a portion of a mark is descriptive, but the entire mark is otherwise registrable, the entire mark will be approved during examination without the need for a disclaimer of the descriptive component. A notable exception applies when the application claims the basis of a foreign registration that includes a disclaimer. Should the mark in its entirety be determined to be descriptive, the application will be rejected for that reason.

– Faster Opposition Proceedings –

During 2007, the Trade-Marks Opposition Board limited the number of extensions at each stage of the proceeding; required "exceptional circumstances" to grant extensions beyond the new limits; and no longer grants extensions based upon the consent of both parties.

NOTABLE DEVELOPMENTS

By Rosemarie B. Tofano

Serbia – All Serbian applications and registrations in existence prior to October 1, 2007 must be re-registered or re-filed in Kosovo. There is presently a deadline of October 1, 2008 for revalidating such trademark rights in Kosovo. Serbian registrations are recognized as enforceable in Montenegro until their expiration date, without requiring re-registration, and Serbian applications pending on May 28, 2008 must be re-filed in Montenegro by November 28, 2008.

Bangladesh – The Trademark law has been amended to provide for service mark registration. This provides the opportunity for protecting retail store services and other often pirated services in Bangladesh. The country now provides for registration in classes 1 to 45 of the International Classification of Goods and Services. All marks that are registrable in the U.S. may now be applied for in Bangladesh.

Portugal – The previously re-occurring obligation to file a Declaration of Intention to Use every five years following registration has been revoked. The new law comes into effect October 1, 2008, but applies to pending applications as of July 25, 2008. The lack of a Declaration of Intention to Use is no longer an available ground to attack a registration regardless of the date of the irregularity.

Singapore – Amendments to the trademark law now allow for recordation of licenses against applications in addition to registrations. And the ability to reinstate an abandoned application due to a missed deadline has been expanded. Generally, reinstatement will be successful if

filed within six months of the missed deadline, if the omission was unintentional, and if the omitted act is supplied. Reinstatement is subject, however, to any intervening filed application for a conflicting mark.

Korea – A recent court decision reversed the longstanding position that product shapes do not function as a trademark. The court recognized the shape of a handbag as a protectable mark as it was unique, had distinctive features that were used exclusively for many years, and such distinctive features were advertised and promoted by the manufacturer. The Court recognized that product shape and color are key aspects of purchasing decisions.

European Union – Color marks per se, namely, marks including colors but no verbal element, are protectable only as to their specific configuration and arrangement of the color elements. Rights in and to the colors are not enforceable based on color emulation alone. Similarity of the graphics, configuration, in addition to the colors, would be necessary for confusion to be found. It would be extremely difficult to enforce color rights per se, even if a large percentage of the purchasing public recognizes the colors per se as a source of origin.

Australia – Cyber squatting increased by over 33 percent during 2007. The registration of domain names that are identical or similar to well known trademarks is considered cyber squatting in Australia, if intended to misdirect internet traffic to illegitimate sites, or to elicit a payment to buy the domain name at an inflated price.

Chile – This country has joined a growing number of jurisdictions improving its customs protection. To fight counterfeit products, Customs officials now have immediate access to the data in the trademark office, including local representative and attorney information. Such representatives are now able to be accredited to act before the Chilean Customs services.

For more information about Foreign Trademarks, please contact: Rosemarie B. Tofano, RTofano@Lackebach.com

Lackebach Siegel LLP

Lackebach Siegel Building
One Chase Road
Scarsdale, New York 10583
U.S.A.

Phone: (914) 723-4300

Fax: (914) 723-4301

E-Mail: mail@Lackebach.com

www.Lackebach.com